

Model JCD-0C

**Indoor/Outdoor Current Transformer
600 V, 10 kV BIL, 1,500-8,000 A, Window Diameter 8.13"**

Application

Designed for both indoor and outdoor service. Suitable for operating meters, instruments and control devices. For use on higher voltage circuits with an insulated primary conductor, please refer to the Applications Information section of catalog GEP-9186.



Regulatory Agency Approvals

UL Recognized Standards File E93779 IEEE C57.13

Reference Drawings

Outline 0121C33762

Weight

(Approximate)
Transformer, Window Type 20 lbs
Mounting Base, add 2 lbs

Insulation Level

0.6 kV; BIL 10 kV full wave

Frequency

50-60 Hz

Model JCD-0C

Current Ratio (Amps) Pri : Sec	ANSI Accuracy Class, 60 Hz, Burden Per ANSI		Relay Class	Relay Class Continuous Thermal Current Rating Factor		Catalog Number	
	BO.1 to BO.9	B1.8		@ 30 °C Amb.	Without Mounting Feet	Stainless Steel Feet Assembled	
Single Ratio							
1,500:5	0.3	0.6	C50	3.0	750X131124	750X131125	
2,000:5	0.3	0.3	C100	2.0	750X131007	750X131033	
3,000:5	0.3	0.3	C100	2.0	750X131009	750X131035	
4,000:5	0.3	0.3	C100	1.5	750X131010	750X131036	
5,000:5	0.3	0.3	C100	1.0	750X131011	750X131037	
6,000:5	0.3	0.3	C100	1.0	750X131012	750X131038	
8,000:5	0.3	0.3	C100	1.0	750X131014	750X131040	
Dual Ratio							
1,000/ 2,000:5	BO.1 to BO.5	B1.8	C50	2.0	750X131016	750X131042	
			C100	2.0			
1500/ 3,000:5	BO.1 to BO.5	B1.8	C50	2.0	750X131017	750X131043	
			C100	2.0			
2,000/ 4,000:5	BO.1 to BO.5	B1.8	C50	2.0	750X131018	750X131044	
			C100	1.5			
3,000/ 6,000:5	BO.1 to BO.5	B1.8	C50	1.33	750X131019	750X131032	
			C100	1.0			



JCD-OC Dimensions

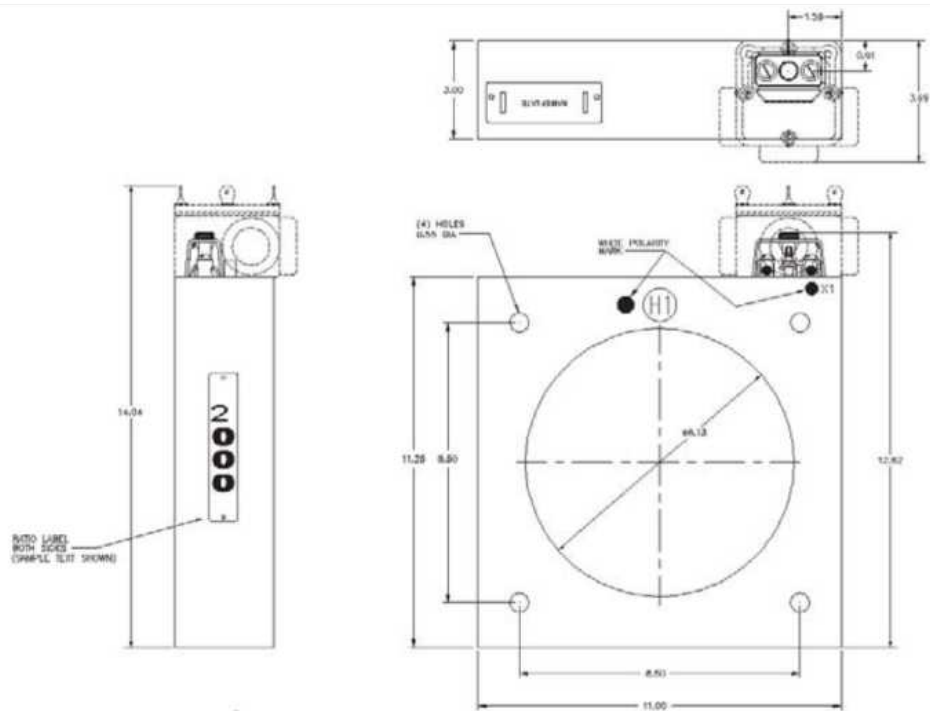

Construction and Insulation

The core and coil are encapsulated in a polyurethane resin. This tough material has excellent electrical and mechanical properties over a wide temperature range and is UV resistant for outdoor use.

Core and Coils

The core is made from high quality grain oriented silicon steel, annealed under rigidly controlled factory conditions. The secondary winding is made of heavy enameled copper wire. The secondary windings are evenly distributed around the core for maximum accuracy and resistance to stray fields from adjacent conductors.

Terminals

Secondary terminals are tin plated brass, compression type with a 0.275" diameter cross-hole for wiring and a 1/4-28 clamp screw. A shorting device is provided and interlocked to the terminal cover. The terminal cover is made of a clear plastic. Provision is made for sealing the cover.

Polarity

Primary and secondary polarity marks are white.

Conduit Attachment

A secondary conduit box, in place of the secondary terminal block, is available. It is suitable for outdoor applications. Box and cover has a gasket and four sealable thumbscrews.

Nameplate

The nameplate is laser engraved aluminum. It is attached to the top of the unit and has provision for attaching the user's identifying tag. The nominal current rating is marked on both faces of the unit in large numerals.

Baseplate and Mounting

The transformer can be mounted in any position. Optional stainless-steel mounting feet are available, they are attached to the transformer with two bolts. If baseplate is not supplied, mounting hardware to be min (2) 1/2 bolts with (4) USS flat washers. Torque value not to exceed 35 ft. lbs.

Maintenance

These transformers require no maintenance, other than occasional cleaning, if installed where air contamination is severe.

Grid-AIS-L4-ITL_Model_JCD_OC-1397-2017_07-EN. © Copyright 2017. General Electric Company and Instrument Transformers LLC reserve the right to change specifications of described products at any time without notice and without obligation to notify any person of such changes.

